



ASSEMBLY/INSTALLATION INSTRUCTION MANUAL



CO-PILOT TRANSMISSION MANAGEMENT COMPUTER . 601-900-9272

2003-2018 RAM HEMI w/ 545 RFE AUTOMATIC TRANSMISSION





**Installation Manual v1.7:
545RFE Co-Pilot TOW Edition Transmission Management Computer
2003-2018 Dodge Ram Hemi
PN: 601-900-9272**



Please read all instructions before installation.

Thank you for purchasing the ATS Co-Pilot Transmission Management Computer. This manual is to assist you with your installation and operation of the unit. If you are installing the unit for a customer, please pass this manual on to your customer for future reference.

BILL OF MATERIALS:

1. Electronics Controller Box, 545RFE Co-Pilot · 601-800-9272
2. Wiring Harness, 545RFE Co-Pilot · 601-011-9272
3. Coil Relay, 545RFE Co-Pilot · 601-023-2326
4. TPS Sensor Adapter, 2003-2005 · 601-016-2272
5. TPS Sensor Adapter, 2006-2018 · 601-016-2317
6. Hardware Kit, 545RFE Co-Pilot · 601-123
7. Diagnostic Jumper · 601-014-2326

INSTALLATION INSTRUCTIONS

WIRING:

Disconnect both the negative ground (- **Black**) and positive (+**Red**) terminals on all vehicle batteries before starting installation. During installation the harness could short out the PCM if you don't properly disconnect the batteries. The ATS 545RFE Tow Co-Pilot is designed to be completely plug and play, meaning there are no wires you have to cut, strip, and splice! This is thanks to the constant development and research we put into our products. The following instructions will be divided up for wiring each individual connector of the Co-Pilot.

It is highly recommended that you use dielectric grease on all connectors that are underneath the vehicle, or under the hood. Connectors that are exposed to the elements, water, and road salts, have a high chance of those elements leaking into the connectors over time. Dielectric grease helps repel water and chemicals that make it into the connectors and help conduct electricity better ensuring that your ATS Diesel Co-Pilot will be reliable and problem free for many years.



NOTE: When routing the Co-Pilot harness, be sure to route the harness away from hot areas in the engine compartment (i.e. exhaust) to avoid damage to the wiring and harness. Reconnect all terminals on batteries after completing installation.

INSTALLING THE HARNESS:

When starting this installation it is important to have everything set out and organized. Proper lighting under the truck will help you see what you are doing and avoid breaking any important connectors while you are working with them. The Co-Pilot harness can be installed easily in any location, whether it's a shop or your driveway. We have found it best to start the install of the harness underneath the truck at the transmission valve body, pressure sensor, and speed signal connectors, and then to pull the harness up the frame rail and secure it with zip ties. From there you can make all of your under hood connections, then route the harness through the firewall and finish the install inside the cab.

The install of the harness should only take about an hour to complete.

VALVE BODY SOLENOID PACK CONNECTORS:

The valve body solenoid pack connector utilizes a “cam lock” design, which uses two tabs on the side of the solenoid pack connector and grooves shaped into the connector lock lever on the harness that plugs into the valve body. While this system is good in theory, we find that the tabs on the solenoid pack connector can easily break off. This is due to years of sand, dirt and debris working it's way into the connectors, making it difficult for them to be removed later on. We highly recommend helping back the connector off with your hand while moving the lock/release lever to avoid any parts breaking.

Make sure the red secondary lock tab is released, which unlocks the white lock/release lever. Pull down on the white lock/release lever while pulling the connector up at the same time.



NOTE: Occasionally the connector has a good seal and is difficult to back off, but working the connector around slightly while pulling up can help break it free. As you pull the white lock/release lever down the connector will push its way up and off of the solenoid pack connector.

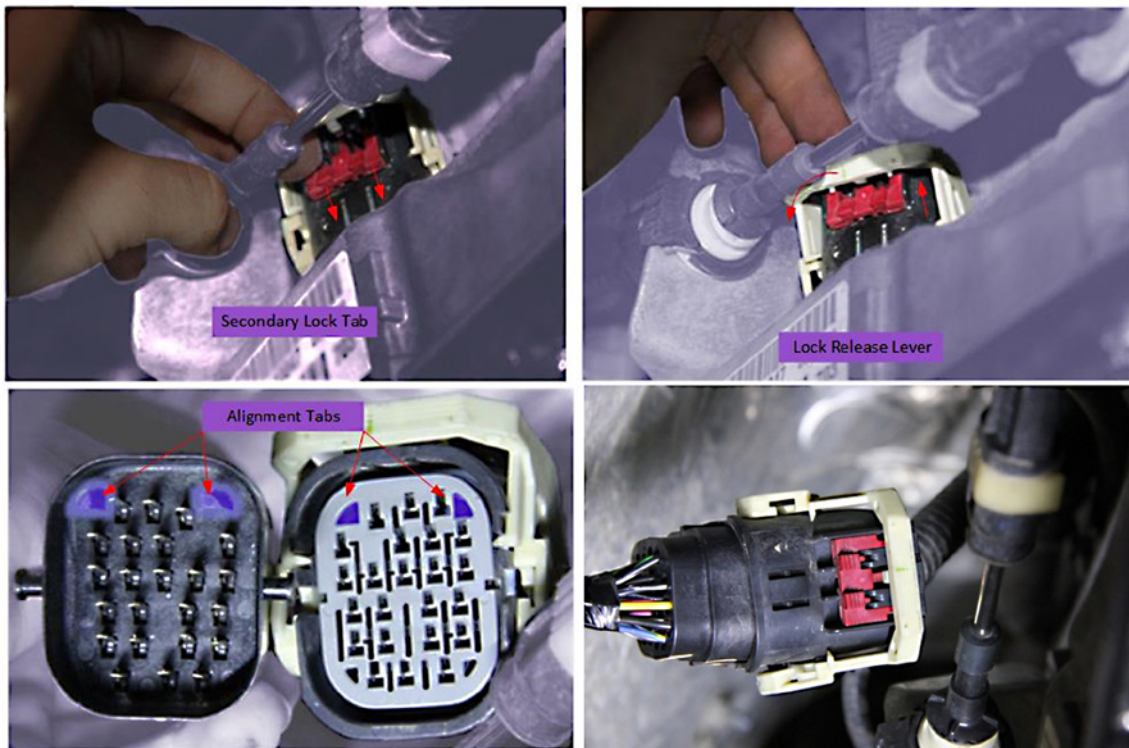

Next we will be plugging in the mating connector on the Co-Pilot harness into the factory harness we just removed. Use caution when installing this connector because the lock tabs on each side can break off easily. Make sure the white lock/release tab is all the way down prior to inserting the black Co-Pilot connector into the valve body harness, as it allows the two lock tabs to be pushed in correctly.

There are two ¼ circle triangle shaped alignment tabs on the male valve body connector on the Co-Pilot harness. These must be facing the same way as the holes on the female valve body connector on the factory harness. When plugging the two connectors together, make sure the white lock/release lever is all the way down, which allows the two lock tabs on the male connector to fit inside the groove of the female connector. Push the two connectors together and pull the white lock/release back at the same time. When the white lock/release connector is all the way at the top you can now move the red secondary lock tab back into its locked position.

VALVE BODY SOLENOID PACK CONNECTORS (cont.):

Finally, install the female valve body connector on the Co-Pilot harness onto the transmission valve body connector. This is done in the same procedure you just performed installing the Co-Pilot harness to the factory harness. Make sure the gray lock/release tab on the Co-Pilot harness is all the way down, line up the connectors, and push down while you move the gray lock/release tab back to the lock position. The female connector on the Co-Pilot harness has a slightly different design than the factory harness; there is no red secondary lock on this connector. The secondary lock on the female Co-Pilot harness is built into the plastic and the gray lock/release lever clips into the plastic behind it when it is all the way in the lock position. To release this secondary lock, simply push down on the black plastic behind the gray lock/release lever.

LINE PRESSURE CONNECTORS:

The last sets of connectors we need to install are the line pressure sensor connectors. This part of the wiring harness can be tossed over the top of the transmission case to reach the passenger side of the transmission. The line pressure sensor is located near the rear of the transmission case on the passenger side of the truck. This connector has a secondary lock system, which is the red tab on the end of the connector. This prevents it from coming loose, but can also cause you a headache if you don't unlock it before trying to remove the connector. To unlock the secondary lock, get a small flathead screwdriver and pop the red tab back. This unlocks the button you need to depress to remove the factory harness from the line pressure sensor. Remove the factory harness from the line pressure sensor, and plug the identical female connector that is on the Co-Pilot harness into the line pressure sensor. Then plug the female connector on the factory harness into the male connector of the Co-Pilot harness, and remember to re-engage the secondary lock tabs on both the female connector of the factory harness, and the female connector of the Co-Pilot harness once you are finished plugging everything in. Be sure to secure these wires away from any exhaust, as an unsecured harness could easily make contact with the hot exhaust system and melt the insulation.



COIL RELAY INSTALLATION:

The Coil Relay is the black plastic relay with a silver tab on it. We have designed the enclosure for the Coil Relay to mount under the hood using a zip tie or bolt. During operation the control box will not get warm with normal use, that is why it can be installed wherever you prefer.

We suggest using the supplied zip tie attach the Coil Relay to the top of the firewall on the tab (as pictured below). It does not need to be attached to a ground point. Route the two pin female connector from the Co-Pilot harness to the Coil Relay, making sure to secure it away from moving components like the steering wheel shaft. Plug the two-pin female connector from the Co-Pilot harness into the two-pin male connector on the Coil Relay.

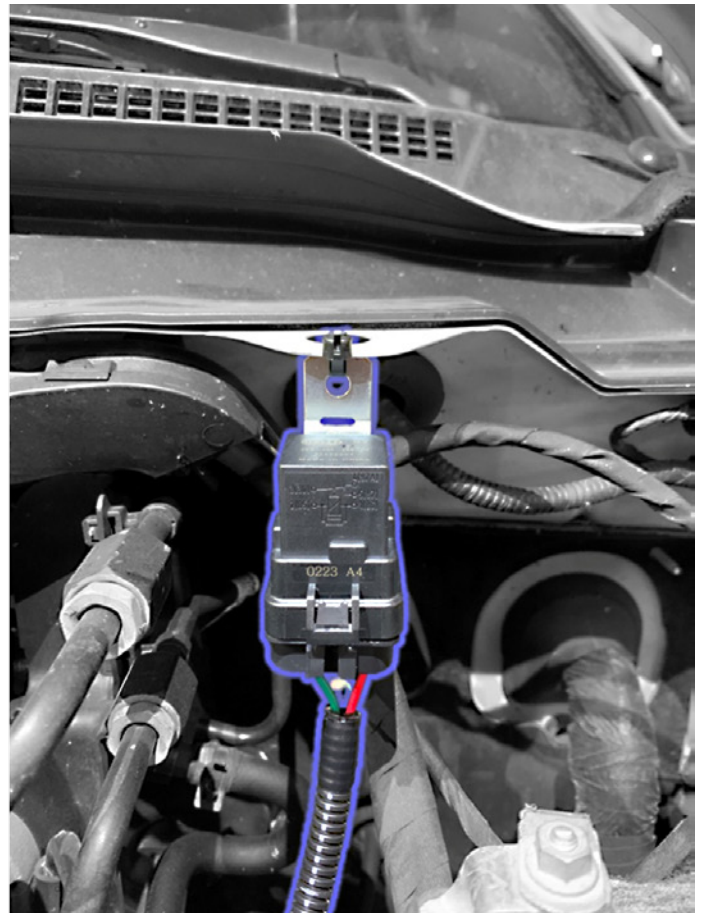

INSERTING THE CO-PILOT WIRING HARNESS THROUGH THE FIREWALL:

The rest of the Co-Pilot harness install takes place inside the cab of the truck. On automatic Dodge Ram trucks the absence of the clutch master cylinder leaves a perfect hole to route the harness through. This hole is covered by a plate, with two studs that end up inside the truck under the dash. Two 15mm nuts hold the plate onto the firewall; remove these 2 nuts to remove the plate.

The first step to feeding the Co-Pilot harness through the firewall is inserting the one-pin pink APPS connector through the hole in the firewall first, as it is rather difficult to get it through the hole after the rest of the harness is already in the hole. After you have inserted the one-pin APPS connector, turn the 24-pin Co-Pilot connector sideways, so it is parallel with the main harness and feed it through the hole in the firewall. Be careful not to scrape any wires on the bare metal of the firewall when you are pulling the harness through. Pull the harness through the firewall until you reach the point where the under hood connections come out of the harness.



NOTE: Included in the hardware pack that came with this kit, is a grommet that is designed to fit in this hole. The installation of the grommet is important; it protects the wires from rubbing on the sharp metal edge which could cause a short circuit. The grommet can either be installed before or after the insertion of the harness through the firewall.

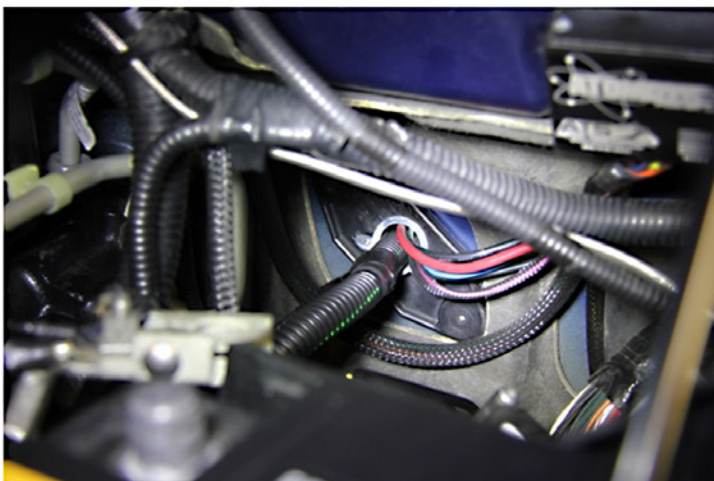
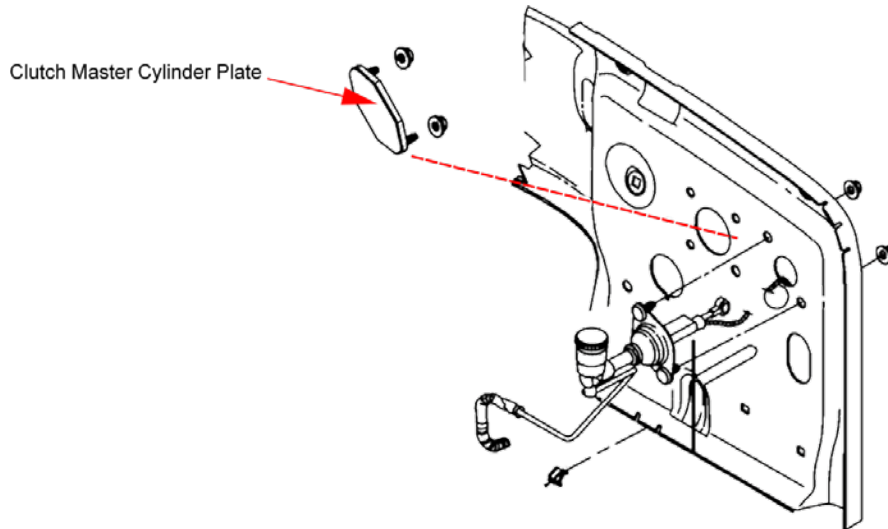

Under hood view



Under dash view

ACCELERATOR PEDAL POSITION SENSOR (APPS):

Now that you have the harness installed under the dash of the truck, we can make the connection to the one sensor in the cab that we watch during the operation of the Co-Pilot. The accelerator pedal position sensor, or throttle position sensor (TPS) is a 6 pin connector that plugs directly into the pedal assembly near the top. We have included an adapter in your kit to make installation simple and easy, especially in a tight and cramped spot like under the dash.

Simply unplug the factory harness, plug our adapter directly into the APPS sensor, and then plug the factory harness into the back of our supplied adapter. There is a single wire with a connector on the end of it that comes out of the supplied adapter. This is meant to plug into the mating one-pin connector that is on the main Co-Pilot harness. If you already pulled the harness through the firewall, this connector should be under the dash. Plug the 2 single pin connectors into each other and zip tie any extra slack out of the way.

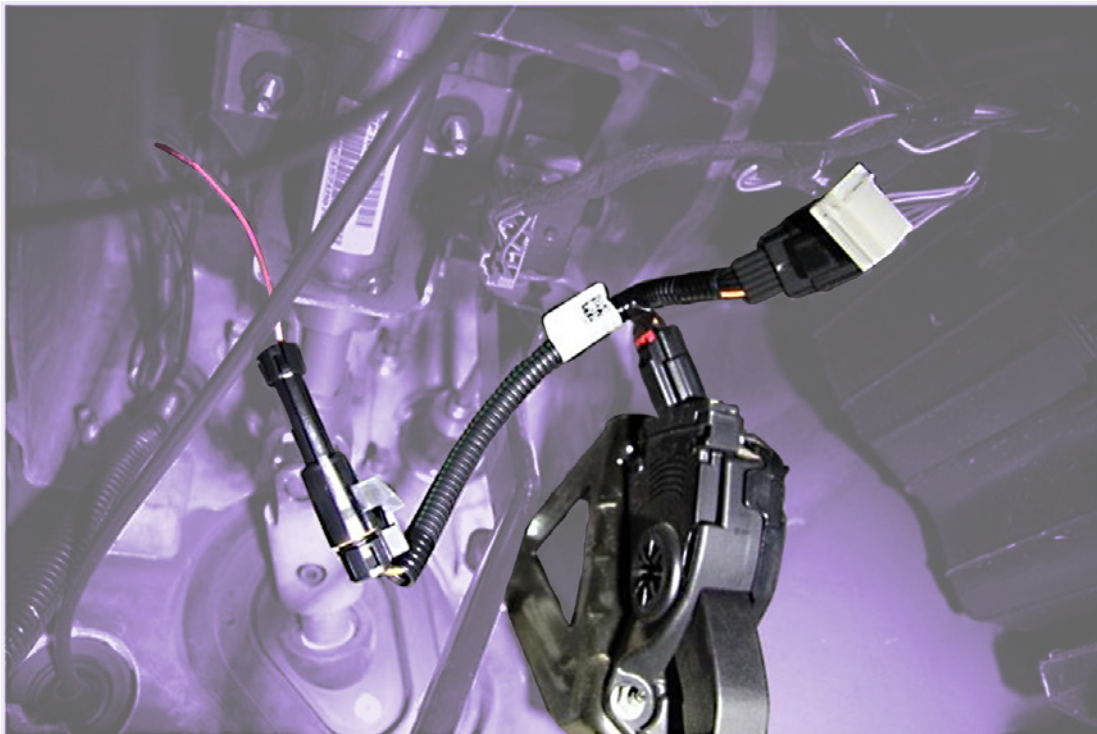
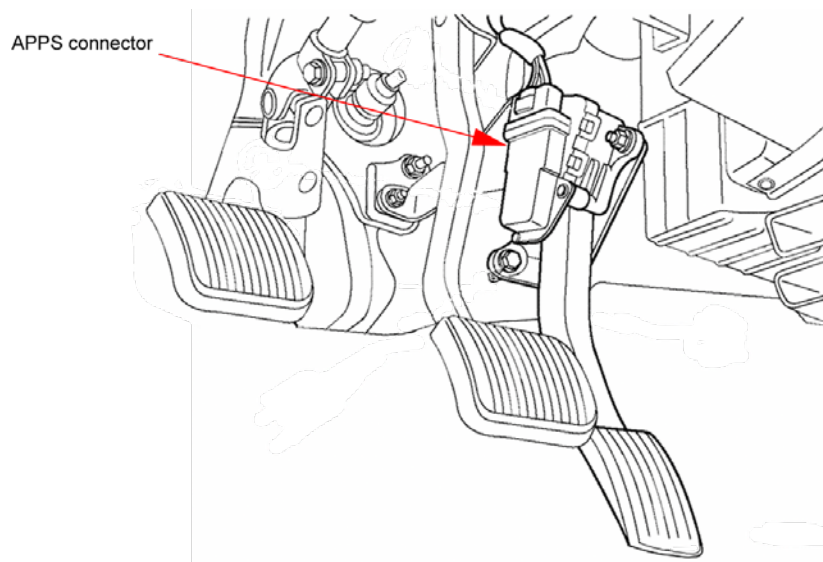

CO-PILOT MOUNTING LOCATION:

Find a convenient location to mount the 24Pin Co-Pilot Controller within reach and view of the driver. We recommend locating the unit just to the right of the driver on the lower dash panel (above the driver's right knee). Use the supplied Velcro to secure it to the dash. Before sticking the Velcro to the dash thoroughly clean the area with a cleaner such as isopropyl alcohol. Apply the isopropyl alcohol to a clean rag or towel and wipe the area clean.



BATTERY GROUND RING TERMINAL:

When installing the ground ring terminal to the battery cable, it is important to make sure that the batteries are still disconnected. Installing the ring terminal to the battery while it is connected can cause power surges from the loose terminals while the nut that secures them is loose and not yet tight, which could cause issues with the Co-Pilot and to any other accessories you have connected to the battery cables. **Grounding the Co-Pilot harness directly to the ground post of the battery is extremely important**, because this eliminated noises in the signals that the Co-Pilot is watching and producing. This will cause erratic operation and in some cases check engine lights.



IMPORTANT! Leave the battery disconnected until the the installation is complete to avoid any check engine lights from being set, and to avoid a short circuit.



UNDERSTANDING THE OPERATION OF THE ATS TOW CO-PILOT:

The ATS Co-Pilot improves shift quality, determining and commanding optimum line pressure and internal clutch timing within the transmission to improve the reliability of the transmission.

The front panel of the ATS Co-Pilot has 3 buttons and a series of LED indicators as shown below.

The ATS 545RFE Co-Pilot has 2 LED display settings. To change these settings, press any button on the front panel of the display. The mode is indicated by the position of the purple lights on the front panel. To change the display mode, simply use the UP and DOWN arrow keys on the front panel to change modes. UP is increasing the mode number and will move lights from right to left. As seen above. DOWN decreases the mode setting, by moving lights from left to right. This can be done while driving.

MODIFYING LINE PRESSURE

When the green light comes on the LED panel, this is indicating we are modifying line pressure.

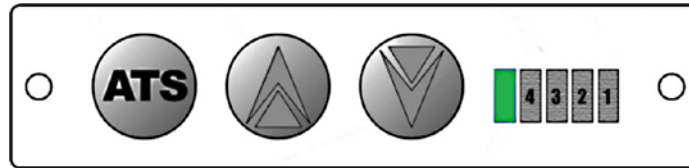

SETTING 1 (Up arrow button, far right purple light)

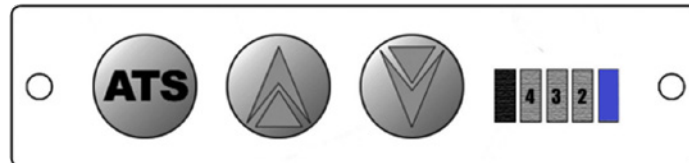

Setting one is going to be displaying your Throttle Position Sensor (TPS). As you're in this setting this will be showing you the throttle positioning (%) of your pedal. The 1st light (right) will be 10%. The 2nd light will be 40%. 3rd light 70%. 4th (left) light, 92%+.

SETTING 2 (Up arrow button, 2nd purple light from far right)

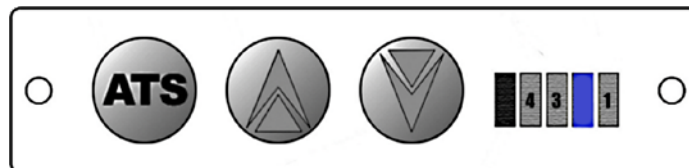

Setting 2 is going to be your true line pressure from sensor. As you're in this setting this will be showing you the true pressure (psi) your transmission is performing at. The 1st light (right) will be 130 psi. The 2nd light will be 160 psi. 3rd light, 190 psi. 4th (left) light, 220 psi.

BRIGHTNESS SETTING

To change the brightness of the front panel, press the ATS button 2 times (all 4 purple lights will illuminate). Then use the UP and DOWN arrows to adjust brightness. Once selected, wait 4-5 seconds and the Co-Pilot will save the brightness setting and return to the normal boost indication screen.

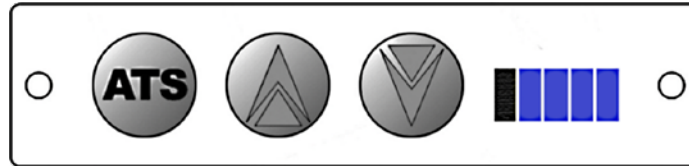

TROUBLESHOOTING:

The ATS 545RFE Co-Pilot incorporates troubleshooting features for the transmission. If the Co-Pilot detects a problem within the transmission, it will flash certain purple lights on the front panel to indicate a problem. If the Co-Pilot flashes the purple lights while driving, refer to the diagram below to diagnose the issue. If the issue is detected by the Co-Pilot and requires further attention, the signal is passed through to the factory computer and a DTC (Diagnostic Trouble Code) will be set in the factory computer. This allows isolation of pressure problems/connectivity issues between the Co-Pilot, transmission and PCM.

LINE PRESSURE TROUBLESHOOTING QUICK GUIDE



LOW PRESSURE CIRCUIT VOLTAGE

Possible open circuit or low fluid level
(will flash with ignition on, engine off)

*(This is because the line pressure cannot be made without the engine running)



LOW LINE PRESSURE

Line pressure too low, check pump and test leak



HIGH PRESSURE CIRCUIT VOLTAGE

Short to reference voltage or faulty sensor



HIGH LINE PRESSURE

Line pressure higher than anticipated



IMPORTANT! Flashing lights on the Co-Pilot should be dealt with promptly. If line pressures are too low, serious transmission damage can occur.



LIMITED WARRANTY STATEMENT:

ATS Diesel Performance warrants the original purchaser that any parts purchased shall be free from defects in material and workmanship. ATS Diesel Performance is the warrantor of this product, in the event this produce is purchased form a distributor or retailer other that ATS Diesel Performance the customer must contact ATS Diesel Performance for any warranty concerns, not the purchasing dealer. A defect is defined as a condition that would render the product inoperable. This warranty does not cover deteriorating of plating, paint or any other coating. ATS liability is limited to the repair or replacement, at ATS's option, of any warrantable product returned prepaid with a complete service history and proof of purchase to the factory. A valid proof of purchase is a dated bill of sale. Repaired or replaced, product will be returned to the customer, freight collect on a like-for-like part number basis. Accepted warranty units, which have been replaced, become the sole property of ATS.

A Return Product Authorization number obtained in advanced from an ATS customer service representative must accompany products returned for warranty determination. ATS will be the final authority on all warranty decisions.

This warranty shall not apply to any unit which has been improperly stored or installed, subjected to misapplication, improper operating conditions, accidents, or neglect; or which has been improperly repaired, altered or otherwise mistreated by the owner or his agent.

This warranty shall terminate at the end of 12 months in service with the original user. Labor cost incurred by the removal and replacement of an ATS product, while performing warranty work, will be the responsibility of the vehicle owner; in no case does the obligation of ATS Diesel Performance exceed the original purchase price of the product as indicated on the original bill of sale.

Except as set forth in this warranty, ATS disclaims any implied warranty, including implied warranties of merchantability and fitness for a particular purpose. ATS also disclaims any liability for incidental or consequential damages including, but not limited to, repair labor, rental vehicles, hotel costs or any other inconvenience costs. This warranty is in lieu of all warranties or guarantees, either expressed or implied, and shall not extend to any customer or to any person other than the original purchaser residing within the boundaries of the continental US or Canada.



NOTE: We strive to make our instructions as clear and complete as possible. To achieve this, our instructions are under constant construction. We encourage you to visit our Technical Support Website (<http://www.atsdiesel.com/ATSWebsite/Technical.asp>) to check for the most up-to-date manuals and diagrams as well as other information. If you have any suggestions as to how we can improve this installation manual, let us know at: suggestions@atsdiesel.com



CONTACT US

ATS Diesel Performance, Inc.
5293 Ward Rd.
Arvada, CO 80002

Toll Free: (800) 949-6002

Local: (303) 431-7973

Fax: (303) 431-0135

Website: www.atsdiesel.com

Email: info@atsdiesel.com



TROUBLESHOOTING:

Thank you for purchasing the ATS Co-Pilot® Tow Edition Transmission Management Computer. This manual is to assist you with your installation and operation of the unit. Please use the contact information to the left for assistance with any questions regarding this installation. If you are installing the unit for a customer, please pass this manual on to your customer for future reference.



NOTES

PATENTED INNOVATION MEANS MORE POWER TO THE GROUND.

ATS WARRANTY
5yr/500k



ATS DIESEL PERFORMANCE
ATS DIESEL PERFORMANCE PATENTED FIVE STAR TORQUE CONVERTER

- PATENTED VISKUS CLUTCH DRIVE SYSTEM FOR INCREASED EFFICIENCY
- BILLET COVER WITH PATENTED SQUARE-TAB DRIVE
- SQUARE-TAB CONSTRUCTION (NOT ROUND)
- VISKUS PISC CQC LASER CUT CLUTCH PLATES
- BILLET PISTON WITH PATENTED FLANK DRIVE TAB DESIGN
- PROPRIETARY ATS EXCLUSIVE CLUTCH FORMULATION W/ UNIQUE BONDING TECHNOLOGY
- REDESIGNED SPRING DAMPENER SUPPORTS INCREASED TORQUE LOADS
- 4340 HARDENED TURBINE SPLINES PROVIDE LONGEVITY AND RELIABILITY
- FULLY WELDED TURBINE AND IMPELLER VALVES
- CQC STATOR WITH HIGH-FLOW WINDOWS INCREASE OIL FLOW PROVIDING INCREASED EFFICIENCY
- FULL ROLLER BEARING CONSTRUCTION BETWEEN HIGH-LOAD AREAS
- 4340 CQC CUT PUMP DRIVE HUB LOCKED INTO IMPELLER HOUSING
- PLASMA WELDED FOR UNSURPASSED STRENGTH



Proudly manufactured in Arvada, Colorado, U.S.A.